

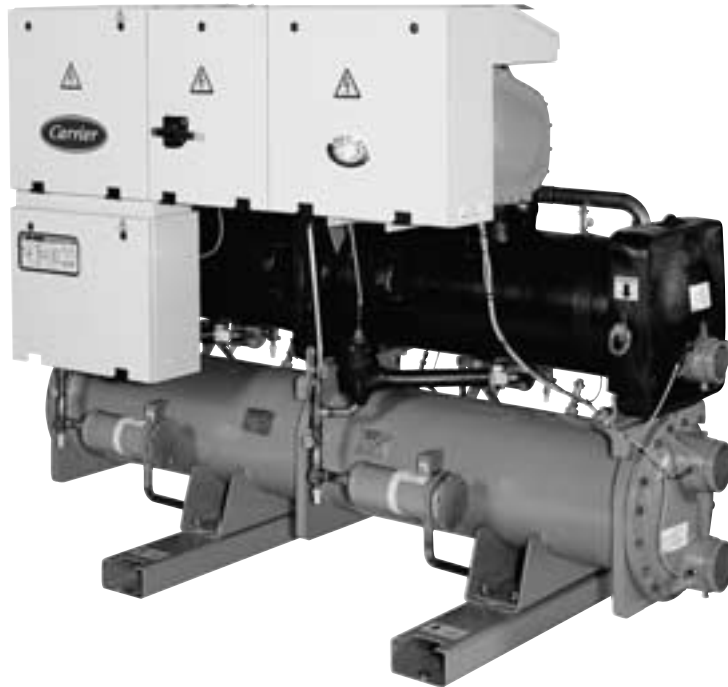

## Water-Cooled Screw Compressor Liquid Chillers

PRO-DIALOG Plus



Carrier is participating in the Eurovent Certification Programme. Products are as listed in the Eurovent Directory of Certified Products.



Quality Management System Approval

## 30HXC - 50 Hz

Nominal cooling capacity 286-1300 kW

The 30HXC units are water-cooled chillers, designed from the ground up to meet the needs of today and tomorrow:

- ecological HFC-134a refrigerant
- screw compressors
- fits through a standard door with no disassembly required.
- mechanically cleanable evaporators and condensers

All units are equipped with PRO-DIALOG Plus control to optimize the efficiency of the refrigerant circuit.

### Features

- Quality design and construction make the 30HXC unit the preferred choice.
- Non-controlled, ozone-benign HFC-134a refrigerant. HCF-134a is a proven, non-toxic, non-flammable refrigerant which will have the highest usage of any new refrigerant.
- Medium-pressure refrigerant HFC-134a minimizes stress on the compressors and ensures their long operating life.
- The 30HXC units are equipped with screw compressors for extremely quiet operation and low-vibration levels.
- The 30HXC units exceed the efficiency level of average industry standards for both full- and part-load operation, saving on operating costs, through lower electrical costs.
- Part of the 30HXC product range is available equipped with

the very low temperature option that permits evaporator leaving water temperatures down to  $-10^{\circ}\text{C}$  with ethylene glycol or down to  $-7^{\circ}\text{C}$  with propylene glycol.

- The 30HXC control is fully automatic. The leaving water temperature is continuously monitored to detect load and flow changes. This combination provides the most precise temperature control available.
- Two independent refrigerant circuits - the second one takes over automatically, when the first one malfunctions, maintaining partial cooling under all circumstances.
- Easy installation - the 30HXC chillers are supplied with a full refrigerant charge, and conveniently located power supply and water inlet and outlet connections.
- Auto-diagnostics - quick display of the machine status.
- Multiple compressor concept for optimized part-load efficiency and minimized starting current.
- Series star/delta starter, limiting the start-up current on 30HXC 080-190 units.
- 30HXC 080-375 units are also available as high condensing temperature and non-reversible heat pump versions (options 150 and 150A). Their application range is the same as for the standard units, on which they are based, but they also allow condenser leaving water temperatures of up to  $63^{\circ}\text{C}$ . PRO-DIALOG control offers all the advantages of the standard units, plus control of the leaving condenser water temperature.

## Easy installation

- The 30HXC has a compact design that fits through a standard door opening and requires minimal indoor space. The 30HXC is supplied as a complete package for easy installation. There are no extra controls, timers, starters or other items to install.
- 30HXC units have a single power point and one main disconnect/isolator switch for sizes 30HXC 080 to 190, and one power point and one main disconnect/isolator switch per circuit for sizes 30HXC 200 to 375.  
The hydraulic connections are simple and facilitated by the use of Victaulic connections for the evaporator and condenser.

## Simple to service

- Mechanically-cleanable evaporator and condenser
- Twin-screw compressors which require minimum routine service or maintenance.
- Easily accessed suction and discharge pressure and temperature information via a display module.

## PRO-DIALOG Plus control

PRO-DIALOG Plus is an advanced numeric control system that combines intelligence with great operating simplicity.

## PRO-DIALOG Plus ensures intelligent leaving water temperature control and optimises energy requirements.

- The PID control algorithm with permanent compensation for the difference between the heat exchanger entering and leaving temperature, anticipates load variations, guarantees leaving water temperature stability and prevents unnecessary compressor cycling.
- The long-stroke electronic expansion valves (EXV), together with refrigerant level control via heat exchange in the evaporator, allows a significant energy efficiency improvement at part load conditions, and faultless chiller operation in a wider temperature range.
- Adjustable ramp loading, according to the inertia of the application, avoids load increases that are too fast and too frequent, increasing unit life and limiting power consumption peaks.
- Several capacity loading possibilities ensure improved start-up at low outdoor air temperature, and permit use of one of the refrigerant circuits as a back-up circuit.

## PRO-DIALOG Plus ensures preventive protection and enhances chiller reliability.

- Equalisation of compressor operating hours
- No capillary tubes or pressostats (except as safety device)
- PRO-DIALOG Plus monitors all chiller safety parameters. The fault history function and the fault codes facilitate immediate location of faults and in certain cases the conditions causing the alarm. Prognostic and preventive maintenance functions (incorrect water loop, oil filter dirty etc.) permit anticipation of possible problems.

## PRO-DIALOG Plus offers extended communications capabilities

- Clear and easy-to-understand operator interface. The LEDs, numeric displays and touch keys are well-positioned on the schematic chiller diagram. The user immediately knows all operating parameters: pressures, temperatures, operating hours, etc.
- The extensive chiller remote control capabilities (wired connection) allow integration into building monitoring systems (see Technical Description)
- RS485 series port for connection to the Carrier Comfort Network (CCN) or any other monitoring system (optional communications interface with open protocol allows transfer of almost 40 parameters).
- Parallel piloting of two units as standard, or of several units with Flotronic System Manager (FSM) and Chiller System Manager (CSM III) options.
- The control permits:
  - Control in master/slave configuration of two units operating in parallel.
  - Programming of operating time schedules (up to 8 periods per week)
  - Programming of operating time schedules for the second set point (up to 8 periods per week)
  - Definition of operating time period with demand limit.
  - Integration of the unit into a building monitoring system (BMS): serial port RS 485.
- Control of the customer's water pump (dual pump with automatic change-over optional).
- Control at the second set point (example: room unoccupied).  
Set point reset as a function of the air temperature or the difference between entering and leaving water temperature.

## Options and accessories

	Option	Accessory
Compressor suction valve	X	
Evaporator with one pass less	X	
Evaporator maximum water-side operating pressure of 21 bar	X	
Reversed evaporator water inlet/outlet	X	
Condenser with one pass less	X	
Condenser maximum water-side operating pressure of 21 bar	X	
Reversed condenser water inlet/outlet	X	
RS485 communications interface with JBus, BacNet, LON protocol		X
Electronic compressor starter (30HXC 200-375)	X	
Electrical protection to IP44C	X	
Low evaporator leaving water temperatures < +4°C to > -6°C	X	
Units for very low temperatures < 0°C to > -10°C	X	
High condensing temperature unit and non-reversible heat pump	X	
Tropicalized control box	X	
Disassembled unit	X	
Evaporator water pump starter	X	
Condenser water pump starter	X	
Three-way valve control, condenser	X	
Heat exchanger water connection kit		X

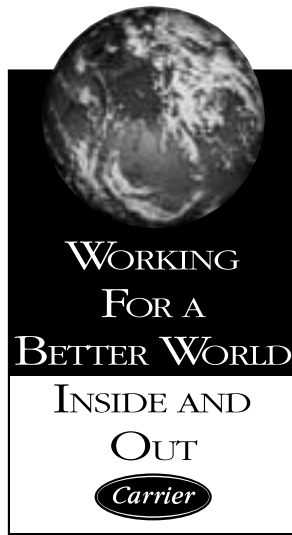

Carrier's environmental leadership



PRO-DIALOG Plus operator interface

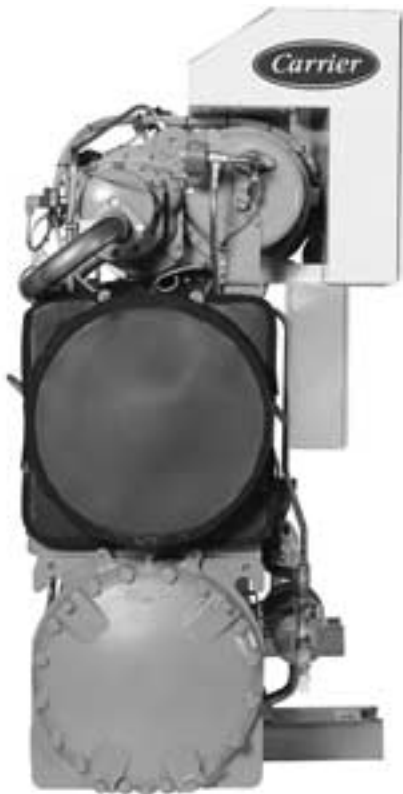

The 30HXC fits through a standard doorway,  
minimizing installation costs



Carrier twin-screw compressor

# Physical data

<b>30HXC</b>		<b>080</b>	<b>090</b>	<b>100</b>	<b>110</b>	<b>120</b>	<b>130</b>	<b>140</b>	<b>155</b>	<b>175</b>	<b>190</b>	<b>200</b>	<b>230</b>	<b>260</b>	<b>285</b>	<b>310</b>	<b>345</b>	<b>375</b>	
<b>Nominal cooling capacity*</b>	kW	286	312	348	374	412	449	509	541	598	651	699	812	897	985	1106	1204	1300	
<b>Operating weight</b>	kg	2274	2279	2302	2343	2615	2617	2702	2712	3083	3179	3873	4602	4656	4776	5477	5553	5721	
<b>Refrigerant charge**</b>		HFC-134a																	
Circuit A**	kg	33	33	32	31	49	51	48	54	54	70	92	115	117	132	109	96	119	
Circuit B**	kg	34	34	30	35	52	47	48	57	50	70	68	63	75	80	106	109	137	
<b>Compressors</b>		Semi-hermetic, twin-screw																	
Quantity - Circuit A		1	1	1	1	1	1	1	1	1	1	2	2	2	2	2	2	2	
Quantity - Circuit B		1	1	1	1	1	1	1	1	1	1	1	1	1	1	2	2	2	
Capacity control		PRO-DIALOG Plus control																	
No. of control steps		6	6	6	6	6	6	6	6	6	6	8	8	8	8	10	10	10	
Minimum step capacity	%	19	19	21	19	21	19	17	19	21	21	14	14	14	14	10	10	10	
<b>Evaporator</b>		Shell and tube with internally finned copper tubes																	
Net water volume	l	50	50	58	69	65	65	75	75	88	88	126	155	170	170	191	208	208	
Water connections		Victaulic connections																	
Inlet/outlet	in	4	4	4	5	5	5	5	5	5	5	6	6	6	6	8	8	8	
Drain and vent (NPT)	in	3/8	3/8	3/8	3/8	3/8	3/8	3/8	3/8	3/8	3/8	3/8	3/8	3/8	3/8	3/8	3/8	3/8	
Max. water side operating pressure	kPa	1000	1000	1000	1000	1000	1000	1000	1000	1000	1000	1000	1000	1000	1000	1000	1000	1000	
<b>Condenser</b>		Shell and tube with internally finned copper tubes																	
Net water volume	l	48	48	48	48	78	78	90	90	108	108	141	190	190	190	255	255	255	
Water connections		Victaulic connections																	
Inlet/outlet	in	5	5	5	5	5	5	5	5	6	6	6	8	8	8	8	8	8	
Drain and vent (NPT)	in	3/8	3/8	3/8	3/8	3/8	3/8	3/8	3/8	3/8	3/8	3/8	3/8	3/8	3/8	3/8	3/8	3/8	
Max. water side operating pressure	kPa	1000	1000	1000	1000	1000	1000	1000	1000	1000	1000	1000	1000	1000	1000	1000	1000	1000	

\* Standard Eurovent conditions: Evaporator entering/leaving water temperature 12°C and 7°C. Condenser entering/leaving water temperature 30°C/35°C.

Evaporator and condenser fouling factor = 0.000044 m<sup>2</sup> K/W.

Not applicable to high condensing temperature units - please refer to electronic selection catalogue.

\*\* The weights shown are guidelines only. For the unit refrigerant charge please refer to the unit nameplate.

# Electrical data

<b>30HXC</b>		<b>080 090 100 110 120 130 140 155 175 190 200 230 260 285 310 345 375</b>																	
<b>Power circuit</b>																			
Nominal power supply (Un)*	V-ph-Hz	400-3-50																	
Voltage range	V	360-440																	
<b>Control circuit supply</b>		The control circuit is supplied via the factory-installed transformer																	
<b>Nominal power input*</b>	kW	53	62	67	76	80	89	102	112	121	129	140	164	192	195	221	250	263	
<b>Nominal current drawn *</b>	A	101	115	127	143	149	168	190	207	226	234	255	294	337	354	399	448	477	
<b>Max. power input**</b>	kW	87	97	108	119	131	144	161	175	192	212	223	257	288	318	350	384	424	
Circuit A	kW	-	-	-	-	-	-	-	-	-	-	144	161	192	212	175	192	212	
Circuit B	kW	-	-	-	-	-	-	-	-	-	-	79	96	96	106	175	192	212	
<b>Max. current drawn (Un - 10%***</b>	A	158	176	195	215	235	259	289	314	344	379	401	461	517	568	628	688	758	
Circuit A	A	-	-	-	-	-	-	-	-	-	-	259	289	344	379	314	344	379	
Circuit B	A	-	-	-	-	-	-	-	-	-	-	142	172	172	189	314	344	379	
<b>Maximum current drawn (Un)***</b>	A	143	160	177	195	213	236	263	285	312	344	365	419	468	516	570	624	688	
Circuit A	A	-	-	-	-	-	-	-	-	-	-	236	263	312	344	285	312	344	
Circuit B	A	-	-	-	-	-	-	-	-	-	-	129	156	156	172	285	312	344	
<b>Maximum starting current, standard unit (Un)****</b>	A	181	206	223	249	267	298	333	355	382	442	841	978	1027	1200	1129	1184	1373	
Circuit A****	A	-	-	-	-	-	-	-	-	-	-	712	822	871	1028	844	871	1028	
Circuit B****	A	-	-	-	-	-	-	-	-	-	-	605	715	715	856	844	871	1028	
<b>Max. starting current/max. current draw ratio, unit</b>	A	1.26	1.28	1.26	1.27	1.25	1.26	1.27	1.24	1.22	1.28	2.31	2.33	2.19	2.32	1.98	1.89	1.99	
Max. starting current/max. current draw ratio, circuit A	A	-	-	-	-	-	-	-	-	-	-	3.02	3.13	2.79	2.99	2.96	2.79	2.99	
Max. starting current/max. current draw ratio, circuit B	A	-	-	-	-	-	-	-	-	-	-	4.70	4.58	4.58	4.97	2.96	2.79	2.99	
<b>Max. starting current - reduced current start (Un) ****</b>	A	std.	std.	std.	std.	std.	std.	std.	std.	std.	std.	636	683	732	824	834	889	997	
Circuit A	A	std.	std.	std.	std.	std.	std.	std.	std.	std.	std.	507	527	576	652	549	576	652	
Circuit B	A	std.	std.	std.	std.	std.	std.	std.	std.	std.	std.	330	370	370	385	549	576	652	
<b>Max. starting current - red. current start/max. current draw ratio, unit</b>	A	std.	std.	std.	std.	std.	std.	std.	std.	std.	std.	1.74	1.63	1.56	1.60	1.46	1.42	1.45	
Circuit A	A	std.	std.	std.	std.	std.	std.	std.	std.	std.	std.	2.15	2.00	1.84	1.89	1.93	1.84	1.89	
Circuit B	A	std.	std.	std.	std.	std.	std.	std.	std.	std.	std.	2.56	2.37	2.37	2.24	1.93	1.84	1.89	
<b>Three-phase short circuit holding current</b>	kA	25	25	25	25	25	25	25	25	25	25	NA	NA	NA	NA	NA	NA	NA	
Circuit A	kA	-	-	-	-	-	-	-	-	-	-	25	25	25	25	25	25	25	
Circuit B	kA	-	-	-	-	-	-	-	-	-	-	15	15	15	15	25	25	25	
<b>Customer standby capacity, unit or circuit B, for evaporator water pump connections†</b>	kW	8	8	8	11	11	11	15	15	15	15	15	18	18	30	30	30	30	

\* Standard Eurovent conditions: Evaporator entering/leaving water temperature 12°C and 7°C. Condenser entering/leaving water temperature 30°C/35°C.

\*\* Power input, compressor, at unit operating limits (evaporator water entering/leaving temperature = 15°C/10°C, condenser entering/leaving water temperature = 45°C/50°C) and a nominal voltage of 400 V (data given on the unit name plate).

\*\*\* Maximum unit operating current at maximum unit power input.

\*\*\*\* Maximum instantaneous starting current (maximum operating current of the smallest compressor(s) + locked rotor current or reduced starting current of the largest compressor)

† Current and power inputs not included in the values above.

N/A Not applicable

# Electrical data for units with high condensing temperatures (option 150/150A)

<b>30HXC</b>		<b>080</b>	<b>090</b>	<b>100</b>	<b>110</b>	<b>120</b>	<b>130</b>	<b>140</b>	<b>155</b>	<b>175</b>	<b>190</b>	<b>200</b>	<b>230</b>	<b>260</b>	<b>285</b>	<b>310</b>	<b>345</b>	<b>375</b>	
<b>Power circuit</b>																			
Nominal power supply (Un)	V-ph-Hz	400-3-50																	
Voltage range	V	360-440																	
<b>Control circuit supply</b>		The control circuit is supplied via the factory-installed transformer																	
<b>Max. power input*</b>	kW	108	122	136	149	163	180	196	213	229	287	278	310	343	431	426	458	574	
Circuit A	kW	-	-	-	-	-	-	-	-	-	-	180	196	229	287	213	229	287	
Circuit B	kW	-	-	-	-	-	-	-	-	-	-	98	114	114	144	213	229	287	
<b>Max. current drawn (Un - 10%)**</b>	A	198	223	247	271	295	325	355	385	415	516	502	562	622	774	770	830	1032	
Circuit A	A	-	-	-	-	-	-	-	-	-	-	325	355	415	516	385	415	516	
Circuit B	A	-	-	-	-	-	-	-	-	-	-	177	207	207	258	385	415	516	
<b>Maximum current drawn (Un)**</b>	A	180	203	225	246	268	295	323	350	377	469	456	512	566	704	700	754	938	
Circuit A	A	-	-	-	-	-	-	-	-	-	-	295	323	377	469	350	377	469	
Circuit B	A	-	-	-	-	-	-	-	-	-	-	161	189	189	235	350	377	469	
<b>Maximum starting current, standard unit (Un)***</b>	A	281	316	338	382	404	437	521	548	576	635	1255	1549	1603	1734	1737	1792	1969	
Circuit A***	A	-	-	-	-	-	-	-	-	-	-	1094	1360	1415	1500	1387	1415	1500	
Circuit B***	A	-	-	-	-	-	-	-	-	-	-	960	1226	1226	1265	1387	1415	1500	
<b>Max. starting current/max. current draw ratio, unit</b>	A	1.56	1.56	1.51	1.55	1.51	1.48	1.62	1.57	1.53	1.35	2.75	3.03	2.83	2.46	2.48	2.38	2.10	
Max. starting current/max. current draw ratio, circuit A	A	-	-	-	-	-	-	-	-	-	-	3.71	4.22	3.75	3.19	3.97	3.75	3.19	
Max. starting current/max. current draw ratio, circuit B	A	-	-	-	-	-	-	-	-	-	-	5.96	6.50	6.50	5.39	3.97	3.75	3.19	
<b>Max. starting current - reduced current start (Un) ***</b>	A	std.	std.	std.	std.	std.	std.	std.	std.	std.	std.	870	933	987	1129	1121	1176	1364	
Circuit A	A	std.	std.	std.	std.	std.	std.	std.	std.	std.	std.	709	744	799	895	771	799	895	
Circuit B	A	std.	std.	std.	std.	std.	std.	std.	std.	std.	std.	435	490	490	510	771	799	895	
<b>Max. starting current - red. current start/max. current draw ratio, unit</b>	A	std.	std.	std.	std.	std.	std.	std.	std.	std.	std.	1.91	1.82	1.75	1.60	1.60	1.56	1.45	
Circuit A	A	std.	std.	std.	std.	std.	std.	std.	std.	std.	std.	2.40	2.31	2.12	1.91	2.21	2.12	1.91	
Circuit B	A	std.	std.	std.	std.	std.	std.	std.	std.	std.	std.	2.70	2.60	2.60	2.17	2.21	2.12	1.91	
<b>Three-phase short circuit holding current</b>	kA	25	25	25	25	25	25	25	25	25	25	N/A	N/A	N/A	N/A	N/A	N/A	N/A	
Circuit A	kA	-	-	-	-	-	-	-	-	-	-	25	25	25	25	25	25	25	
Circuit B	kA	-	-	-	-	-	-	-	-	-	-	15	15	15	15	25	25	25	
<b>Customer standby capacity, unit or circuit B, for evaporator water pump connections†</b>	kW	8	8	8	11	11	11	15	15	15	15	15	18	18	30	30	30	30	

\* Power input, compressor, at unit operating limits (evaporator water entering/leaving temperature = 15°C/10°C, condensing temperature = 68°C) and a nominal voltage of 400 V (data given on the unit name plate).

\*\* Maximum unit operating current at maximum unit power input.

\*\*\* Maximum instantaneous starting current (maximum operating current of the smallest compressor(s) + locked rotor current or reduced starting current of the largest compressor)

† Current and power inputs not included in the values above

N/A Not applicable

## NOTES for electrical data:

- 30HXC 080-190 units have a single power connection point; 30HXC 200-375 units have two connection points.
- The control box includes the following standard features:
  - Starter and motor protection devices for each compressor
  - Control devices

## Field connections:

- All connections to the system and the electrical installations must be in full accordance with all applicable codes.
- The Carrier 30HXC units are designed and built to ensure conformance with local codes. The recommendations of European standard EN 60204-1 (corresponds to IEC 60204-1) (machine safety - electrical machine components - part 1: general regulations) are specifically taken into account, when designing the electrical equipment.

## Electrical reserves:

Circuit B has disconnect switches and branch sections, designed to supply the evaporator and condenser pump power input.

## IMPORTANT:

- Generally the recommendations of IEC 60364 are accepted as compliance with the requirements of the installation directives. Conformance with EN 60204-1 is the best means of ensuring compliance with the Machines Directive and § 1.5.1.
- Annex B of EN 60204-1 describes the electrical characteristics used for the operation of the machines.

1. The operating environment for the 30HXC units is specified below:

- Environment\* - Environment as classified in IEC 60364 § 3:
  - ambient temperature range: +5°C to +40°C, class AA4\*
  - humidity range (non-condensing)\*:
    - 50% relative humidity at 40°C
    - 90% relative humidity at 20°C
  - altitude: ≤ 2000 m
  - indoor installation
  - presence of water: class AD2\* (possibility of water droplets)
  - presence of hard solids, class AE2\* (no significant dust present)
  - presence of corrosive and polluting substances, class AF1 (negligible)
  - vibration and shock, class AG2, AH2
- Competence of personnel, class BA4\* (trained personnel - IEC 60364)

2. Power supply frequency variation: ± 2 Hz.

3. The neutral (N) conductor must not be connected directly to the unit (if necessary use a transformer).

4. Overcurrent protection of the power supply conductors is not provided with the unit.

5. The factory-installed disconnect switch(es)/circuit breaker(s) is (are) of a type suitable for power interruption in accordance with EN 60947 (corresponds to IEC 60947-3).

6. The units are designed for connection to TN networks (IEC 60364). For IT networks the earth connection must not be at the network earth. Provide a local earth, consult competent local organisations to complete the electrical installation.

## NOTE:

If particular aspects of an actual installation do not conform to the conditions described above, or if there are other conditions which should be considered, always contact your local Carrier representative.

\* The protection level required to conform to this class is IP21B (according to reference document IEC 60529). All 30HXC units are protected to IP23C and fulfil this protection condition.

# Operating limits

## Condenser water flow rates

30HXC	Minimum flow rate, l/s*		Maximum flow rate, l/s**
	Closed loop	Open loop	
080-110	2.3	7.0	28.2
120-130	3.1	9.3	37.1
140-155	3.7	11.1	44.5
175-190	4.3	13.0	51.9
200	4.9	14.8	59.2
230-285	6.7	20.1	80.4
310-375	8.0	24.0	95.9

\* Based on a velocity of 0.3 m/s in a closed loop and 0.9 m/s in an open loop.

\*\* Based on a water velocity of 3.6 m/s.

## Evaporator water flow rates

30HXC	Minimum flow rate, l/s	Maximum flow rate, l/s
080-090	5.2	20.8
100	6.5	25.9
110	7.4	29.6
120-130	8.3	33.4
140-155	9.4	37.8
175-190	11.5	45.9
200	14.1	56.3
230	16.3	65.2
260-285	18.3	73.4
310	20.9	83.7
345-375	23.0	91.9

## Unit operating range at full load

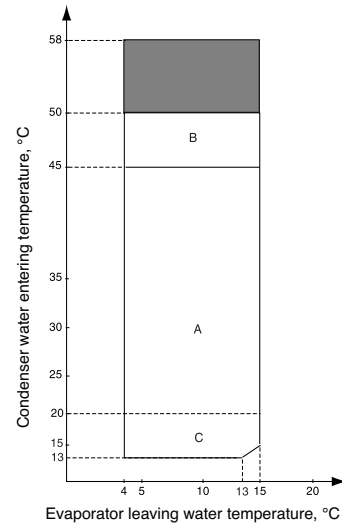

### Notes:

1. Evaporator and condenser  $\Delta T = 5$  K
  2. For start-up at full load with a condenser water entering temperature below 20°C, a three-way valve must be used to maintain the correct condensing temperature
  3. Maximum condenser water leaving temperature 50°C (at full load)
- A** Standard unit operating at full load.  
**B** Standard unit operating at reduced load.  
**C** For transient operating modes (start-up and part load) the unit can operate down to a condenser entering water temperature of 13°C.  
 Units operating with head pressure control with analogue water control valve

■ Additional operating range for high condensing temperature units and non-reversible heat pumps.

# Operating limits, units for very low temperature (option 6)

## Evaporator water flow rate (l/s) with 35% ethylene glycol

30HXC	Minimum flow rate, l/s*	Maximum flow rate, l/s**
090	8.0	15.7
110	10.6	21.3
130	12.4	25.1
155	14.5	28.1
175	15.6	33.0
200	20.5	38.0
230	21.0	39.7
260	24.1	48.3
310	29.6	62.0
345	30.2	63.0

\* Based on a Reynolds number of 4000

\*\* Based on a water velocity of 3.6 m/s

## Evaporator water flow rate (l/s) with 30% propylene glycol

30HXC	Minimum flow rate, l/s*	Maximum flow rate, l/s**
090	11.1	15.7
110	14.2	21.3
130	16.7	25.1
155	19.1	28.1
175	21.1	33.0
200	25.1	38.0
230	27.4	39.7
260	32.3	48.3
310	40.0	62.0
345	40.6	63.0

\* Based on a Reynolds number of 4000

\*\* Based on a water velocity of 3.6 m/s

For very low temperature applications the amount of anti-freeze solution added is critical for the unit operation. The following amounts are required:

Evaporator leaving water temperature, °C	Ethylene glycol, %	Propylene glycol, %
-6	25	27
-7	28	30
-8	30	N/A
-9	33	N/A
-10	35	N/A

## Operating range, 30% propylene glycol

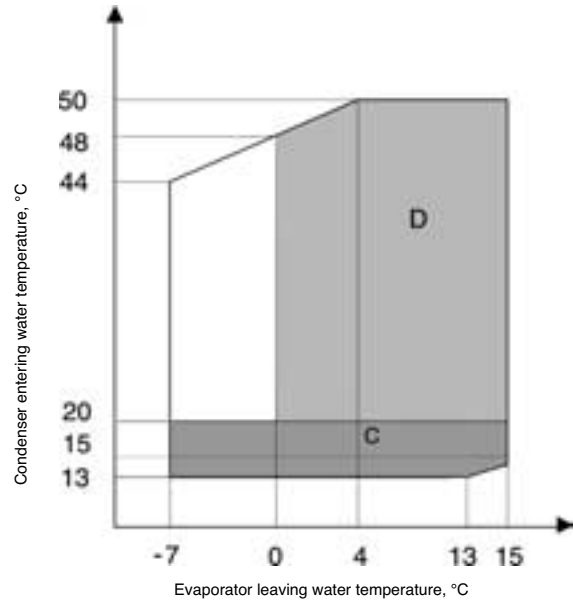

## Operating range, 35% ethylene glycol

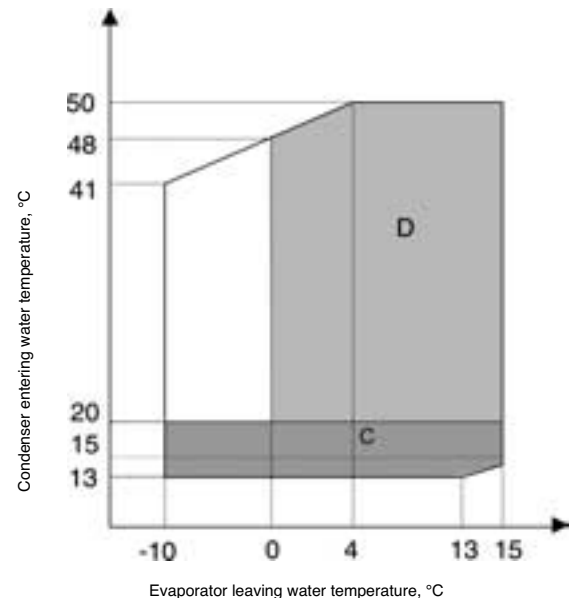

### Notes:

1. Evaporator  $\Delta T = 4$  K max. - condenser  $\Delta T = 5$  K
2. Operating range applicable for full and reduced load.
3. At full load with a condenser water entering temperature below 20°C, a three-way valve must be used to maintain the correct condensing temperature.

### Legend

- C** Unit operating with condensing pressure control with an analogue water control valve.  
For transient operating modes (start-up and part load), the unit can operate down to a condenser entering water temperature of 13°C.
- D** Operation permitted, but performance is not optimized.

# Dimensions/clearances

## 30HXC 080-190

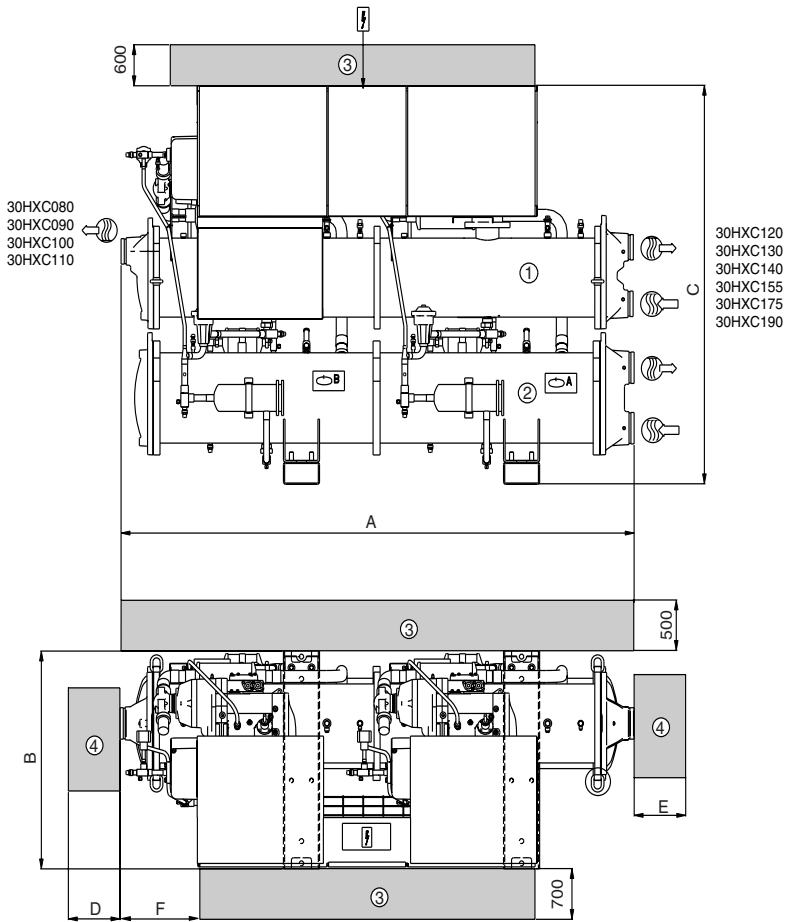

30HXC	A	B	C	D	E	F
080-090-100	2558	980	1800	2200	1000	385
110	2565	980	1850	2200	1000	385
120-130-140-155	3275	980	1816	2990	1000	689
175-190	3275	980	1940	2990	1000	689

### Legend:

All dimensions are given in mm.

- ① Evaporator
- ② Condenser
- ③ Required clearances for maintenance
- ④ Recommended space for tube removal (clearances D and E can be either on the right or the left hand side).
- Water inlet
- Water outlet
- Power supply

### NOTE:

For a specific installation, consult the certified dimensional drawings, available on request.

## 30HXC 200-375

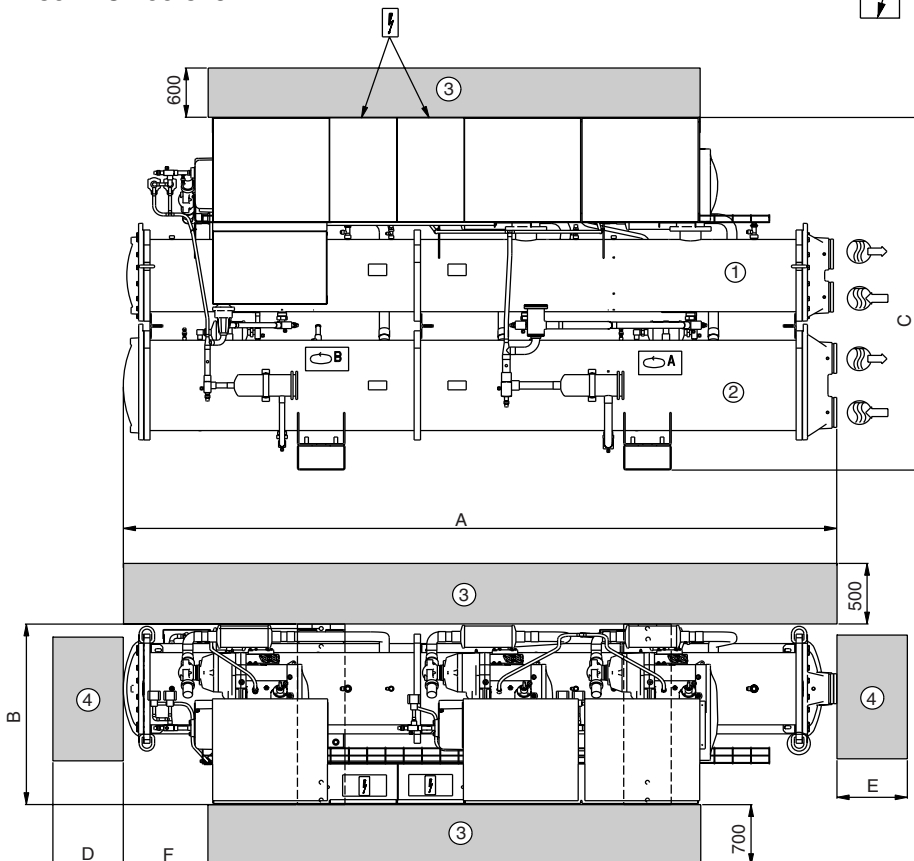

30HXC	A	B	C	D	E	F
200	3903	1015	1980	3600	1000	489
230-260-285	3924	1015	2060	3600	1000	489
310-345-375	4533	1015	2112	4200	1000	503

# Guide specifications

Water-cooled liquid chillers  
Size range: 286 to 1300 kW  
Carrier model number: 30HXC

## Part 1 - General

### 1.01 System description

- Microprocessor controlled, water-cooled liquid chiller utilizing HFC-134a, dual refrigeration circuit, screw compressors and electronic expansion valves.

### 1.02 Quality assurance

- Unit shall be rated in accordance with Eurovent standard.
- Unit construction shall comply with European directives:
  - Pressurised equipment directive (PED) 97/23/EC
  - Machinery directive 98/37/EC, modified
  - Low voltage directive 73/23/EEC, modified
  - Electromagnetic compatibility directive 89/336/EEC, modified, and the applicable recommendations of European standards:
  - Machine safety: electrical equipment in machines, general regulations, EN 60204-1
  - Electromagnetic emission EN 50081-2
  - Electromagnetic immunity EN 50082-2.
- Unit shall be designed, manufactured and tested at a facility with a quality assurance system certified ISO 9001.
- Unit shall be manufactured at a facility with an environment management system certified ISO 14001.
- Unit shall be run tested at the factory.

### 1.03 Delivery, storage and handling

- Unit controls shall be capable of withstanding 55°C storage temperatures in the control compartment.

## Part 2 - Products

### 2.01 Equipment

- General
  - Factory assembled, single-piece, water-cooled liquid chiller. Contained within the unit cabinet shall be all factory wiring, piping, controls, refrigerant charge (HFC-134a), required prior to field start-up.
- Compressors
  - Semi-hermetic twin-screw compressors with internal muffler and check valve.
  - Each compressor shall be equipped with a discharge shut-off valve.
  - Capacity control shall be provided by pilot-operated solenoid valve, capable of reducing unit capacity to 20% of full load. Compressor shall start in unloaded condition.
  - Motor cooling shall be provided by direct liquid injection and protected by internal overload thermistor.
  - Lube oil system shall include pre-filter and internal filter capable of filtration to 3 microns.
- Evaporator
  - Unit shall be equipped with a single evaporator.
  - Shall be manufactured, tested and stamped in accordance with the European directive for pressurised equipment 97/93/EC. The maximum refrigerant-side operating pressure will be 2500 kPa, and the maximum water-side pressure will be 1000 kPa.
  - Shall be mechanically cleanable shell-and-tube type with removable heads.
  - Tubes shall be internally-enhanced, seamless-copper type, and shall be rolled into tube sheets.
- Shall be equipped with Victaulic water connections (water connection kit on demand).
- Shell shall be insulated with 19-mm closed-cell, polyvinyl-chloride foam with a maximum K factor of 0.28. For the very low temperature option this insulation is 38 mm thick.
- Shall have an evaporator drain and vent.
- Design shall incorporate 2 independent refrigerant circuits.
- Shall incorporate a refrigerant level control system.
- Condenser
  - Unit shall be equipped with a single condenser.
  - Shall be manufactured, tested and stamped in accordance with the European directive for pressurised equipment 97/93/EC. The maximum refrigerant-side operating pressure will be 2500 kPa, and the maximum water-side pressure will be 1000 kPa.
  - Shall be mechanically cleanable shell-and-tube type with removable heads.
  - Tubes shall be internally-enhanced, seamless-copper type, and shall be rolled into tube sheets.
  - Shall be equipped with Victaulic water connections (water connection kit on demand).
  - Design shall incorporate 2 independent refrigerant circuits and the oil separator.
- Refrigeration circuits
  - Refrigerant circuit components shall include oil separators, high and low side pressure relief devices (according to applicable standards), discharge and liquid line shutoff valves, filter driers, moisture indicating sight glasses, expansion devices, refrigerant economizers (unit sizes 190, 285, 375), and complete operating charge of both HFC-134a refrigerant and compressor oil.
- Controls, Safeties, and Diagnostics
  1. Controls
    - a. Unit controls shall include as a minimum: the microprocessor, the LOCAL/OFF/REMOTE/CCN selector and a 6-digit diagnostic display (scroll-down text) with keypad.
    - b. Shall be capable of performing the following functions:
      - Automatic change-over between the main compressor and the non-active compressor(s).
      - Capacity control based on leaving chilled fluid temperature with return fluid temperature sensing.
      - Limit the chilled fluid temperature pull-down rate at start-up to an adjustable range of 0.1°C to 1.1°C per minute to prevent excessive demand spikes at start-up.
      - Enable adjustment of leaving chilled water temperature according to the return water temperature or by means of a 0-10 V signal.
      - Provide a dual set point for the leaving chilled water temperature activated by a remote contact closure signal.
      - Enable a 2-level demand limit control (between 0 and 100%), activated by a remote contact closure or a 0 to 10 V signal.
      - Control evaporator water pump, safety pump (if installed), and the condenser pump.
      - Enable automatic changeover in the main phase or shutdown of two chillers in a single system.
      - With two time scheduling programs enable unit start-up control and set-point change.

## 2. Diagnostics

- a. Display module shall be capable of displaying set points, system status (including temperatures, pressures, currents for each compressor, run times and percent loading), and any alarm or alert conditions.
- b. The control shall allow a quick test of all machine elements to verify the correct operation of every switch, circuit breaker, contactor etc. before the chiller is started.
- c. The control shall be capable of balancing the compressor operating times and the number of compressor start-ups.
- d. EXV control, based on throttling (Carrier patent) optimises evaporator charging, ensuring condenser superheat and subcooling.

## 3. Safeties

Unit shall be equipped with all necessary components, and in conjunction with the control system shall provide the unit with protection against the following:

- Loss of refrigerant charge.
- Reverse rotation.
- Low chilled fluid temperature.
- Low oil pressure.
- Current imbalance.
- Thermal overload.
- High pressure.
- Electrical overload.
- Loss of phase.

## ■ Operating characteristics

- Unit shall be capable of starting up with 13°C entering water temperature to the condenser.
- Unit shall be capable of starting up with 25°C entering water temperature to the evaporator.

## ■ Electrical characteristics

- Unit electrical power supply shall enter the unit at one (30HX 080-190) or two locations.
- Unit shall operate on 3-phase power supply without neutral.
- Unit with two compressors (30HX 080-190) shall have a factory-installed, star-delta starter to limit electrical inrush current.
- Control voltage shall be supplied by a factory installed transformer.
- Unit shall be supplied with factory-installed, electrical disconnect switch/circuit breaker.

## ■ Finishing

Electrical cabinet colour: RAL 7035

Compressor/heat exchanger colour: RAL 7037



Order No. 13179-20, 01.2006. Supersedes order No. 13179-20, 01.2003.  
Manufacturer reserves the right to change any product specifications without notice.



Environmental Management System Approval

Manufactured by: Carrier S.C.S. - Montluel, France.  
Printed on Totally Chlorine Free Paper.  
Printed in the Netherlands.