



Carrier is participating in the Eurovent Certification Programme. Products are as listed in the Eurovent Directory of Certified Products.

42GW

Nominal cooling capacity 2-11 kW

Nominal heating capacity 4-14 kW

The Carrier 42GW hydronic cassette offers a modern solution for a wide variety of small and medium sized commercial and residential applications.

It is ideally suited for large offices, data centres, shops, restaurants and bars, hotel receptions, meeting rooms, photographic studios, banks, laboratories and showrooms. As the units have connections for fresh air ducts they can ease problems caused by smoking. The 42GW is normally installed in suspended ceilings and offers two, three or four-way air diffusion. The units maintain precise temperature and humidity conditions preventing draughts and stale air zones. The elegant air inlet grille blends aesthetically with any room decor.

The Carrier hydronic cassette is available in six sizes with cooling capacities from 2.4-11.0 kW and heating capacities from 4,0 to 14 kW, suitable for a wide range of applications.

The units can be supplied from a chiller, a heat pump or a boiler, satisfying a wide range of design requirements. System installation is fast and economical.

Features

- Four-way air distribution gives individual comfort while for localised control each diffuser may be adjusted or even shut down completely.
- The unique design of the centrifugal fan ensures extra-quiet operation.
- The special design of the diffuser ensures rapid blending of the supply and room air. Conditioned air is directed along the ceiling then evenly distributed throughout the room. Return air enters the cassette unit through a large grille. It is then cleaned by an easily removable, washable synthetic filter, treated and recirculated.
- State-of-the-art high performance filters to extract impurities from the air. Washable filters are supplied as standard. In addition, electrostatic and activated carbon filters are also available as optional extras to reduce airborne bacteria, dust, pollen and smoke or odours respectively.
- High-performance condensate drain pump encased in a special sound-insulating material removes condensate quietly and fast.
- The low-profile 42GW is light and easy to install. The small chassis fits neatly with standard ceiling tiles and is simple to install wherever it is needed.
- All the key components are accessible from the bottom, simply by removing the grille. The fan can also be removed without disturbing the other components or any surrounding ceiling tiles.
- Four different control options are available with different levels of technical sophistication to ensure maximum user comfort.
- Units available in three versions:
 - 42GWC: 2-pipe version
 - 42GWD: 4-pipe version
 - 42GWE: 2-pipe version with electric heater

Physical and electrical data

Model		42GWC 004 42GWE 004	42GWC 008 42GWE 008	42GWC 010 42GWE 010	42GWC 012 42GWE 012	42GWC 016 42GWE 016
Total cooling capacity	kW	2.4	4.0	4.7	5.9	8.3
Sensible cooling capacity	kW	2.4	3.3	3.9	4.8	6.3
Water flow rate (cooling)	l/s	0.11	0.19	0.22	0.28	0.39
Water pressure drop (cooling)	kPa	9	12	20	19	14
Heating capacity	kW	3.8	5.5	6.6	8.5	10.6
Electric heaters (42GWE models)	kW	1.5	2.5	2.5	3.0	3.0
Air flow (low-medium-high)*	l/s	100/125/183	86/136/194	131/167/236	153/214/306	153/253/361
Power input	W	70	85	95	85	120
Current drawn	A	0.24	0.30	0.40	0.35	0.48
Weight, unit	kg	19	20	20	41	43
Weight, grille	kg	2.5	2.5	2.5	5.0	5.0
Power supply**	V-ph-Hz	230-1-50	230-1-50	230-1-50	230-1-50	230-1-50

Model		42GWC 020 42GWE 020	42GWD 004	42GWD 008	42GWD 010	42GWD 020
Total cooling capacity	kW	11.0	1.9	3.4	4.0	9.8
Sensible cooling capacity	kW	8.5	1.9	2.9	3.4	7.9
Water flow rate (cooling)	l/s	0,52	0,09	0,16	0,19	0,47
Water pressure drop (cooling)	kPa	25	9	12	16	27
Heating capacity	kW	14.4	1.2	3.0	3.5	13.7
Electric heaters (42GWE models)	kW	3.0	-	-	-	-
Air flow (low-medium-high)*	l/s	194/339/486	100/125/183	86/136/194	131/167/236	194/339/486
Power input	W	200	70	85	110	180
Current drawn	A	0.63	0.24	0.30	0.40	0.63
Weight, unit	kg	46	19	20	20	46
Weight, grille	kg	5.0	2.5	2.5	2.5	5.0
Power supply**	V-ph-Hz	230-1-50	230-1-50	230-1-50	230-1-50	230-1-50

The above data refers to Eurovent conditions.

Cooling conditions: 27°C db/19°C wb entering air temperature, 7°C/12°C entering and leaving water temperature at high fan speed

Heating conditions (2 pipes): 20°C entering air temperature, 50°C entering water temperature, same water flow rate as in cooling, at high fan speed.

Heating conditions (4 pipes): 20°C entering air temperature, 70°C/60°C entering and leaving water temperature at high fan speed.

* Air flow values are for units with filters. They do not apply to ductable units.

** The electric motors are 3-speed hermetic type motors with permanent capacitors. They are suitable for tropical climates.

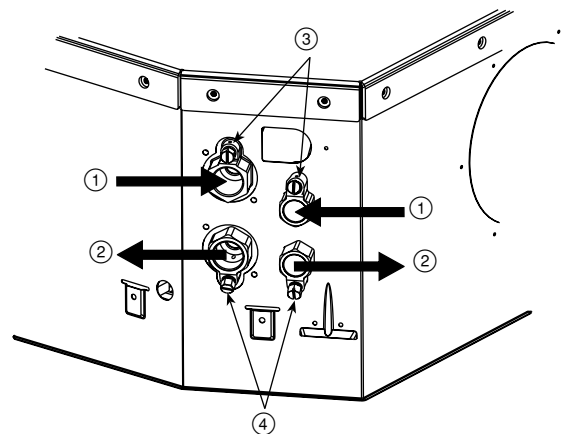

Water connections

- ① – Water inlet
- ② – Water outlet
- ③ – Air purge valve
- ④ – Drainage valve

42GW	Connection diameter inch	Drainage connection diameter inch
004	3/4	1
008	3/4	1
008*	1/2	1
010	3/4	1
010*	1/2	1
012	1	1
016	1	1
020	1	1
020*	3/4	1

* Four-pipe hot water circuits

Dimensions, mm

42GW 004-008-010

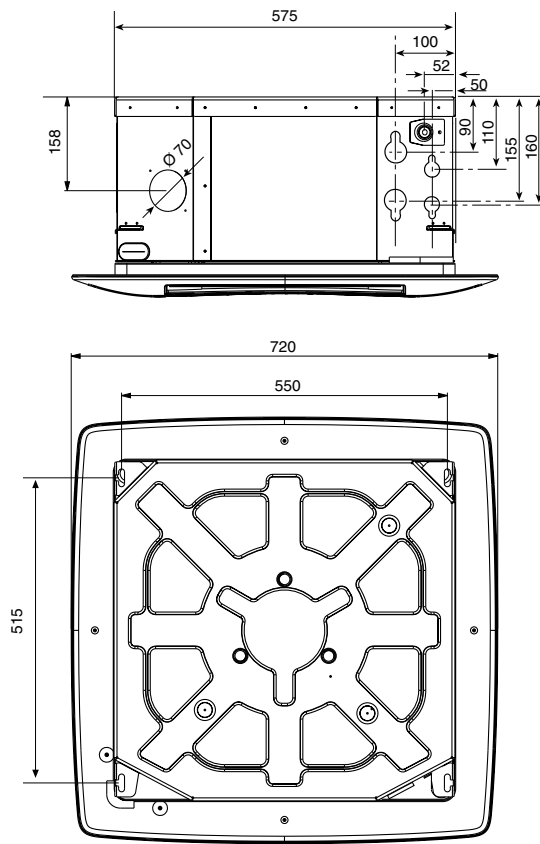
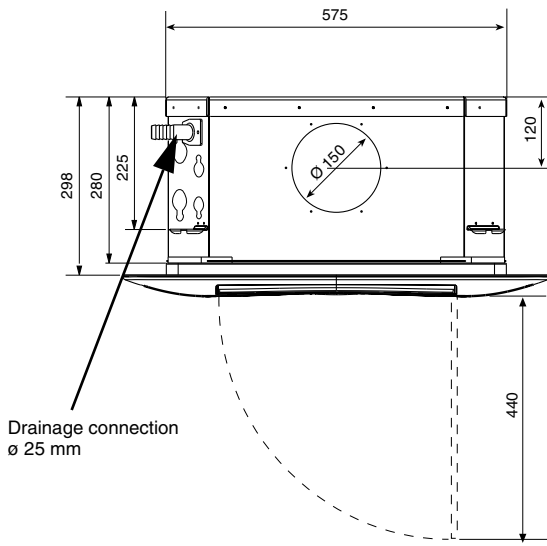

42GW 012-016-020

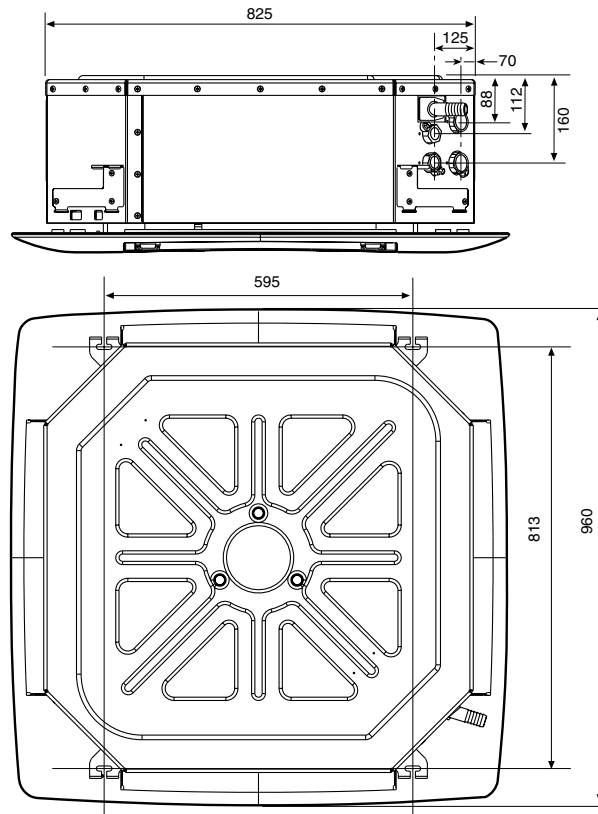
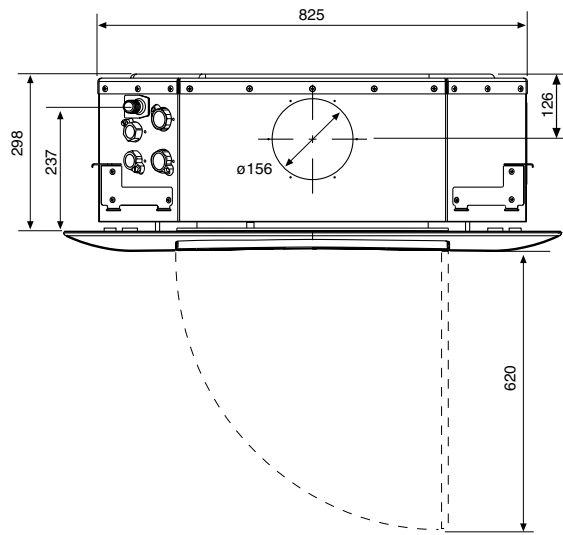

Cooling capacities, two-pipe coil (with fan at high speed)

Entering water temp., °C	Water temp. rise, K	Entering air temperature, °C		42GW 004		42GW 008		42GW 010		42GW 012		42GW 016		42GW 020	
		wb	db	Total	Sensible	Total	Sensible	Total	Sensible	Total	Sensible	Total	Sensible	Total	Sensible
5	3	15	21	2.23	2.09	3.61	2.92	4.23	3.46	5.17	4.17	7.12	5.50	9.44	7.40
5	5	15	21	1.64	1.64	2.52	2.38	2.97	2.83	4.00	3.54	5.53	4.72	7.33	6.37
5	7	15	21	1.08	1.08	1.71	1.71	2.00	2.00	2.92	2.91	4.06	3.97	5.38	5.32
5	9	15	21	0.70	0.70	1.14	1.14	1.23	1.23	2.07	2.07	3.08	3.08	4.02	4.02
7	3	15	21	1.83	1.83	2.77	2.52	3.26	3.00	4.10	3.63	5.51	4.73	7.34	6.40
7	5	15	21	1.29	1.29	1.95	1.95	2.34	2.34	3.06	3.05	4.09	4.00	5.45	5.39
7	7	15	21	0.73	0.73	1.23	1.23	1.42	1.42	2.22	2.22	3.10	3.10	4.15	4.15
7	9	15	21	0.52	0.52	0.84	0.84	0.90	0.90	1.58	1.58	2.29	2.29	2.86	2.86
9	3	15	21	1.47	1.47	2.14	2.14	2.54	2.54	3.11	3.10	4.04	4.00	5.43	5.43
9	5	15	21	0.93	0.93	1.43	1.43	1.68	1.68	2.37	2.37	3.16	3.16	4.23	4.23
9	7	15	21	0.50	0.50	0.81	0.81	0.88	0.88	1.51	1.51	2.22	2.22	2.91	2.91
9	9	15	21	0.36	0.36	0.56	0.56	0.59	0.59	1.11	1.11	1.47	1.47	1.86	1.86
11	3	15	21	1.11	1.11	1.65	1.65	1.95	1.95	2.44	2.44	3.16	3.16	4.25	4.25
11	5	15	21	0.57	0.57	0.92	0.92	1.07	1.07	1.66	1.66	2.25	2.25	3.01	3.01
13	3	15	21	0.74	0.74	1.13	1.13	1.34	1.34	1.76	1.76	2.27	2.27	1.24	1.24
5	3	17	23	3.11	2.39	4.73	3.31	5.53	3.91	6.86	4.76	9.34	6.27	12.39	8.41
5	5	17	23	2.05	1.94	3.52	2.76	4.13	3.27	5.28	4.06	7.52	5.44	9.98	7.33
5	7	17	23	1.47	1.47	2.28	2.17	2.71	2.60	3.99	3.41	5.74	4.64	7.59	6.25
5	9	17	23	0.91	0.91	1.56	1.56	1.80	1.80	2.81	2.79	4.11	3.89	5.42	5.22
7	3	17	23	2.40	2.09	3.82	2.90	4.46	3.43	5.51	4.15	7.56	5.45	9.99	7.33
7	5	17	23	1.67	1.67	2.66	2.38	3.12	2.83	4.19	3.53	5.80	4.68	7.69	6.31
7	7	17	23	1.12	1.12	1.76	1.75	2.06	2.06	2.96	2.90	4.19	3.94	5.53	5.30
7	9	17	23	0.70	0.70	1.14	1.14	1.26	1.26	2.11	2.11	3.08	3.08	4.07	4.07
9	3	17	23	1.84	1.84	2.79	2.53	3.28	3.00	4.14	3.63	5.54	4.71	7.36	6.38
9	5	17	23	1.32	1.32	1.99	1.99	2.38	2.38	3.07	3.05	4.10	4.01	5.46	5.40
9	7	17	23	0.77	0.77	1.27	1.27	1.47	1.47	2.28	2.28	3.12	3.12	4.18	4.18
9	9	17	23	0.53	0.53	0.84	0.84	0.90	0.90	1.58	1.58	2.28	2.28	2.87	2.87
11	3	17	23	1.49	1.49	2.15	2.15	2.55	2.55	3.12	3.11	4.02	4.00	5.42	5.42
11	5	17	23	0.96	0.96	1.46	1.46	1.74	1.74	2.41	2.41	3.16	3.16	4.24	4.24
11	7	17	23	0.50	0.50	0.81	0.81	0.90	0.90	1.55	1.55	2.22	2.22	2.94	2.94
11	9	17	23	0.18	0.18	0.27	0.27	0.29	0.29	1.11	1.11	1.46	1.46	1.86	1.86
13	3	17	23	1.13	1.13	1.66	1.66	1.96	1.96	2.45	2.45	3.15	3.15	4.25	4.25
13	5	17	23	0.60	0.60	0.95	0.95	1.10	1.10	1.70	1.70	2.26	2.26	3.03	3.03
13	7	17	23	0.33	0.33	0.52	0.52	0.56	0.56	1.02	1.02	1.39	1.39	1.78	1.78
13	9	17	23	0.18	0.18	0.27	0.27	0.29	0.29	0.60	0.60				
5	3	19	25	4.05	2.67	6.04	3.73	7.07	4.40	8.67	5.33	11.73	7.04	15.64	9.47
5	5	19	25	2.93	2.22	4.75	3.16	5.58	3.75	7.20	4.69	9.93	6.23	13.19	8.36
5	7	19	25	1.85	1.78	3.36	2.58	3.92	3.06	5.33	3.91	7.89	5.36	10.45	7.21
5	9	19	25	1.30	1.30	2.12	2.01	2.46	2.36	3.96	3.27	5.94	4.55	7.82	6.11
7	3	19	25	3.32	2.38	5.05	3.29	5.89	3.89	7.32	4.73	9.95	6.23	13.19	8.36
7	5	19	25	2.13	1.92	3.76	2.75	4.40	3.26	5.69	4.05	8.01	5.40	10.63	7.28
7	7	19	25	1.51	1.51	2.38	2.17	2.87	2.61	4.22	3.41	6.07	4.60	8.02	6.20
7	9	19	25	0.97	0.97	1.61	1.60	1.87	1.87	2.90	2.77	4.28	3.85	5.62	5.19
9	3	19	25	2.57	2.08	4.04	2.87	4.72	3.40	5.88	4.13	8.04	5.41	10.62	7.27
9	5	19	25	1.70	1.70	2.80	2.36	3.28	2.80	4.39	3.51	6.14	4.64	8.13	6.26
9	7	19	25	1.17	1.17	1.81	1.79	2.13	2.11	3.13	2.90	4.38	3.90	5.76	5.25
9	9	19	25	0.70	0.70	1.15	1.15	1.31	1.31	2.18	2.18	3.09	3.09	4.12	4.12
11	3	19	25	1.88	1.81	3.08	2.48	3.58	2.94	4.44	3.56	6.10	4.63	8.07	6.25
11	5	19	25	1.35	1.35	2.06	2.00	2.43	2.37	3.28	2.99	4.40	3.92	5.83	5.30
11	7	19	25	0.82	0.82	1.31	1.31	1.52	1.52	2.34	2.34	3.14	3.14	4.21	4.21
11	9	19	25	0.53	0.53	0.84	0.84	0.90	0.90	1.58	1.58	2.27	2.27	2.89	2.89
13	3	19	25	1.50	1.50	2.19	2.11	2.58	2.51	3.30	3.03	4.33	3.91	5.75	5.30
13	5	19	25	0.99	0.99	1.49	1.49	1.79	1.79	2.44	2.44	3.16	3.16	4.25	4.25
13	7	19	25	0.50	0.50	0.83	0.83	0.95	0.95	1.61	1.61	2.22	2.22	2.97	2.97
13	9	19	25	0.36	0.36	0.56	0.56	0.59	0.59	1.11	1.11	1.46	1.46	1.85	1.85
5	3	19	27	4.03	3.05	6.03	4.18	7.06	4.95	8.63	5.97	11.66	7.82	15.52	10.52
5	5	19	27	2.91	2.60	4.87	3.67	5.72	4.35	7.16	5.32	9.92	7.03	13.18	9.47
5	7	19	27	2.22	2.22	3.63	3.13	4.25	3.71	5.74	4.67	8.14	6.25	10.79	8.43
5	9	19	27	1.69	1.69	2.62	2.57	3.08	3.03	4.53	4.05	6.45	5.50	8.52	7.41
7	3	19	27	3.31	2.76	5.09	3.77	5.95	4.46	7.29	5.37	9.89	7.01	13.13	9.44
7	5	19	27	2.40	2.35	4.00	3.28	4.70	3.90	5.90	4.76	8.30	6.27	11.00	8.47
7	7	19	27	1.89	1.89	2.91	2.79	3.45	3.33	4.73	4.17	6.51	5.53	8.62	7.47
7	9	19	27	1.36	1.36	2.14	2.14	2.51	2.51	3.63	3.61	5.00	4.83	6.62	6.48
9	3	19	27	2.61	2.50	4.18	3.37	4.89	4.00	5.90	4.79	8.08	6.24	10.71	8.41
9	5	19	27	2.07	2.07	3.14	2.92	3.68	3.46	4.84	4.25	6.51	5.55	8.64	7.50
9	7	19	27	1.55	1.55	2.34	2.34	2.81	2.81	3.73	3.69	5.01	4.85	6.68	6.55
9	9	19	27	1.02	1.02	1.66	1.66	1.93	1.93	2.96	2.96	4.01	4.01	5.37	5.37
11	3	19	27	2.21	2.21	3.28	3.00	3.85	3.57	4.79	4.27	6.38	5.51	8.46	7.46
11	5	19	27	1.72	1.72	2.55	2.54	3.02	3.01	3.80	3.75	4.97	4.86	6.65	6.57
11	7	19	27	1.21	1.21	1.85	1.85	2.18	2.18	3.08	3.08	4.04	4.04	5.42	5.42
11	9	19	27	0.71	0.71	1.19	1.19	1.37	1.37	2.25	2.25	3.10	3.10	4.16	4.16
13	3	19	27	1.86	1.86	2.64	2.64	3.12	3.12	3.77	3.77	4.83	4.81	6.53	6.53
13	5	19	27	1.37	1.37	2.07	2.07	2.44	2.44	3.14	3.14	4.04	4.04	5.44	5.44
13	7	19	27	0.86	0.86	1.35	1.35	1.57	1.57	2.39	2.39	3.15	3.15	4.22	4.22
13	9	19	27	0.53	0.53	0.84	0.84	0.90	0.90	1.59	1.59	2.26	2.26	2.91	2.91

Cooling capacities, two-pipe coil (with fan at high speed)

Entering water temp., °C	Water temp. rise, K	Entering air temperature, °C		42GW 004		42GW 008		42GW 010		42GW 012		42GW 016		42GW 020	
		wb	db	Total	Sensible	Total	Sensible	Total	Sensible	Total	Sensible	Total	Sensible	Total	Sensible
5	3	21	29	5.04	3.33	7.42	4.59	8.70	5.43	10.55	6.52	14.18	8.57	18.91	11.52
5	5	21	29	3.97	2.91	6.17	4.05	7.19	4.79	9.13	5.91	12.50	7.81	16.54	10.46
5	7	21	29	2.66	2.42	4.82	3.49	5.64	4.14	7.36	5.18	10.49	6.95	13.94	9.37
5	9	21	29	2.07	2.07	3.44	2.95	4.12	3.54	5.82	4.53	8.53	6.16	11.29	8.30
7	3	21	29	4.31	3.04	6.42	4.15	7.51	4.92	9.21	5.93	12.43	7.77	16.53	10.45
7	5	21	29	3.19	2.61	5.21	3.65	6.08	4.33	7.72	5.32	10.61	7.00	14.03	9.40
7	7	21	29	2.22	2.19	3.88	3.12	4.54	3.70	6.01	4.64	8.61	6.19	11.42	8.35
7	9	21	29	1.74	1.74	2.72	2.60	3.21	3.08	4.78	4.05	6.80	5.45	8.98	7.35
9	3	21	29	3.54	2.74	5.41	3.74	6.32	4.43	7.78	5.34	10.55	6.97	14.00	9.38
9	5	21	29	2.49	2.36	4.23	3.26	4.96	3.88	6.22	4.73	8.67	6.21	11.50	8.39
9	7	21	29	1.93	1.93	3.04	2.77	3.56	3.29	4.96	4.15	6.86	5.48	9.07	7.41
9	9	21	29	1.41	1.41	2.19	2.18	2.57	2.57	3.72	3.57	5.16	4.80	6.83	6.46
11	3	21	29	2.74	2.45	4.40	3.34	5.13	3.96	6.26	4.74	8.57	6.17	11.36	8.34
11	5	21	29	2.09	2.09	3.29	2.91	3.86	3.45	5.05	4.22	6.82	5.48	9.08	7.43
11	7	21	29	1.59	1.59	2.40	2.38	2.86	2.84	3.87	3.66	5.16	4.80	6.86	6.51
11	9	21	29	1.07	1.07	1.71	1.71	2.00	2.00	3.02	3.02	4.02	4.02	5.40	5.40
13	3	21	29	2.21	2.21	3.44	2.96	4.02	3.52	4.97	4.22	6.68	5.45	8.86	7.37
13	5	21	29	1.74	1.74	2.59	2.54	3.05	3.01	3.93	3.71	5.11	4.80	6.81	6.52
13	7	21	29	1.24	1.24	1.89	1.89	2.24	2.24	3.12	3.12	4.04	4.04	5.43	5.43
13	9	21	29	0.72	0.72	1.23	1.23	1.42	1.42	2.32	2.32	3.12	3.12	4.20	4.20
5	3	23	31	6.12	3.61	8.92	5.00	10.48	5.91	12.59	7.07	16.86	9.31	22.53	12.50
5	5	23	31	5.01	3.17	7.61	4.44	8.88	5.24	11.17	6.46	15.22	8.57	20.19	11.46
5	7	23	31	3.80	2.73	6.24	3.89	7.32	4.62	9.59	5.82	13.29	7.74	17.64	10.39
5	9	23	31	2.55	2.33	4.74	3.32	5.53	3.94	7.54	5.03	11.10	6.87	14.71	9.24
7	3	23	31	5.38	3.31	7.92	4.57	9.29	5.40	11.25	6.48	15.12	8.52	20.16	11.44
7	5	23	31	4.26	2.90	6.59	4.03	7.67	4.75	9.77	5.88	13.36	7.77	17.67	10.40
7	7	23	31	2.96	2.45	5.21	3.50	6.09	4.15	8.02	5.21	11.26	6.93	14.95	9.33
7	9	23	31	2.06	2.05	3.75	2.96	4.39	3.52	6.13	4.51	9.09	6.11	12.03	8.24
9	3	23	31	4.60	3.02	6.86	4.13	8.02	4.89	9.83	5.90	13.26	7.72	17.64	10.38
9	5	23	31	3.47	2.62	5.56	3.63	6.45	4.29	8.26	5.29	11.35	6.96	14.97	9.33
9	7	23	31	2.34	2.22	4.17	3.12	4.88	3.70	6.41	4.62	9.20	6.15	12.20	8.31
9	9	23	31	1.79	1.79	2.83	2.60	3.39	3.12	5.04	4.04	7.18	5.40	9.48	7.29
11	3	23	31	3.79	2.73	5.75	3.70	6.71	4.39	8.31	5.31	11.27	6.92	14.94	9.32
11	5	23	31	2.58	2.32	4.50	3.24	5.24	3.84	6.65	4.71	9.25	6.17	12.21	8.31
11	7	23	31	1.96	1.96	3.21	2.77	3.76	3.29	5.20	4.13	7.23	5.43	9.56	7.34
11	9	23	31	1.46	1.46	2.26	2.23	2.65	2.62	3.93	3.56	5.40	4.74	7.10	6.40
13	3	23	31	2.93	2.44	4.66	3.30	5.44	3.92	6.69	4.72	9.14	6.13	12.08	8.26
13	5	23	31	2.11	2.11	3.46	2.87	4.06	3.41	5.27	4.18	7.20	5.43	9.55	7.35
13	7	23	31	1.62	1.62	2.48	2.41	2.94	2.87	4.06	3.64	5.41	4.75	7.14	6.44
13	9	23	31	1.12	1.12	1.76	1.76	2.06	2.06	3.08	3.07	4.06	4.03	5.42	5.41
5	3	25	33	7.29	3.87	10.52	5.40	12.38	6.38	14.78	7.60	19.72	10.03	26.40	13.46
5	5	25	33	6.14	3.43	9.22	4.84	10.77	5.70	13.36	7.00	18.11	9.30	24.07	12.43
5	7	25	33	5.02	3.04	7.83	4.30	9.10	5.06	11.85	6.39	16.30	8.53	21.55	11.39
5	9	25	33	3.61	2.57	6.26	3.72	7.32	4.41	9.98	5.68	14.11	7.66	18.74	10.29
7	3	25	33	6.54	3.58	9.53	4.97	11.19	5.87	13.44	7.02	18.00	9.25	24.04	12.41
7	5	25	33	5.38	3.16	8.16	4.42	9.51	5.21	11.95	6.42	16.26	8.51	21.56	11.39
7	7	25	33	4.18	2.76	6.74	3.89	7.85	4.60	10.36	5.82	14.28	7.72	18.87	10.33
7	9	25	33	2.72	2.30	5.17	3.34	6.03	3.96	8.28	5.08	11.95	6.85	15.83	9.22
9	3	25	33	5.75	3.29	8.47	4.54	9.93	5.36	12.02	6.44	16.15	8.46	21.53	11.36
9	5	25	33	4.57	2.89	7.05	4.01	8.20	4.72	10.45	5.85	14.28	7.72	18.88	10.33
9	7	25	33	3.28	2.47	5.61	3.49	6.57	4.14	8.72	5.22	12.10	6.90	16.01	9.28
9	9	25	33	2.19	2.08	4.08	2.97	4.76	3.53	6.57	4.50	9.75	6.08	12.89	8.20
11	3	25	33	4.92	3.00	7.34	4.11	8.58	4.86	10.50	5.86	14.18	7.67	18.84	10.31
11	5	25	33	3.74	2.61	5.93	3.60	6.89	4.26	8.86	5.27	12.15	6.92	16.01	9.27
11	7	25	33	2.46	2.24	4.46	3.10	5.21	3.68	6.87	4.60	9.84	6.11	13.04	8.25
11	9	25	33	1.84	1.84	3.03	2.61	3.62	3.13	5.30	4.02	7.62	5.36	10.07	7.25
13	3	25	33	4.05	2.71	6.14	3.68	7.16	4.35	8.89	5.27	12.05	6.88	15.97	9.25
13	5	25	33	2.83	2.33	4.81	3.22	5.56	3.81	7.14	4.68	9.89	6.13	12.99	8.23
13	7	25	33	1.99	1.99	3.36	2.74	3.94	3.26	5.45	4.10	7.66	5.38	10.13	7.28
13	9	25	33	1.51	1.51	2.32	2.24	2.74	2.66	4.14	3.55	5.66	4.69	7.47	6.35

Cooling capacities, four-pipe coil

To obtain the cooling capacities for four-pipe coils, multiply the values from the table above for two-pipe coils by the following correction factors

42GW	Correction factor
004	0.79
008	0.85
010	0.84
020	0.89

Correction factors

42GW	Capacity	Fan Speed		
		High	Medium	Low
004	Total	1	0.76	0.65
	Sensible	1	0.73	0.62
008	Total	1	0.71	0.48
	Sensible	1	0.71	0.47
010	Total	1	0.75	0.61
	Sensible	1	0.73	0.58
012	Total	1	0.76	0.57
	Sensible	1	0.75	0.57
016	Total	1	0.74	0.49
	Sensible	1	0.73	0.47
020	Total	1	0.74	0.42
	Sensible	1	0.73	0.40

Heating capacities, two-pipe coil (at high fan speed)

Water flow rate		Available temp. difference K	42GW 004	42GW 008	42GW 010	42GW 012	42GW 016	42GW 020
l/h	l/s							
252	0.07	20	2.12	2.47	2.72	3.63	3.59	3.95
324	0.09	20	2.32	2.80	3.12	4.12	4.17	4.69
410	0.11	20	2.51	3.10	3.49	4.53	4.73	5.42
486	0.14	20	2.63	3.29	3.73	4.79	5.11	5.96
684	0.19	20	2.84	3.61	4.15	5.21	5.83	7.02
803	0.22	20	2.93	3.74	4.33	5.37	6.12	7.49
1012	0.28	20	3.04	3.90	4.55	5.56	6.50	8.11
1404	0.39	20	3.17	4.09	4.81	5.75	6.92	8.85
1868	0.52	20	3.27	4.21	4.98	5.89	7.19	9.36
2000	0.56	20	3.29	4.23	5.01	5.91	7.25	9.46
3000	0.83	20	3.38	4.35	5.18	6.04	7.51	9.95
4000	1.11	20	3.43	4.40	5.26	6.11	7.64	10.25
324	0.09	30	3.53	4.24	4.71	6.23	6.29	7.03
410	0.11	30	3.80	4.70	5.28	6.88	7.17	8.18
486	0.14	30	3.99	4.99	5.65	7.29	7.78	9.01
684	0.19	30	4.33	5.50	6.31	7.97	8.90	10.65
803	0.22	30	4.47	5.72	6.60	8.22	9.37	11.44
1012	0.28	30	4.65	5.98	6.96	8.52	10.01	12.34
1404	0.39	30	4.86	6.28	7.38	8.86	10.60	13.53
1868	0.52	30	4.99	6.47	7.66	9.07	11.10	14.43
2000	0.56	30	5.02	6.51	7.72	9.11	11.20	14.53
3000	0.83	30	5.18	6.70	7.99	9.32	11.59	15.42
4000	1.11	30	5.26	6.79	8.13	9.42	11.79	15.82
324	0.09	40	4.77	5.76	6.40	8.38	8.42	9.40
410	0.11	40	5.14	6.36	7.14	9.25	9.58	10.95
486	0.14	40	5.39	6.74	7.63	9.81	10.41	12.04
684	0.19	40	5.83	7.42	8.51	10.74	11.89	14.33
803	0.22	40	6.01	7.69	8.88	11.03	12.49	15.22
1012	0.28	40	6.25	8.04	9.35	11.43	13.28	16.52
1404	0.39	40	6.51	8.42	9.90	11.82	14.17	18.11
1868	0.52	40	6.70	8.67	10.27	12.12	14.77	19.20
2000	0.56	40	6.74	8.72	10.37	12.21	14.96	19.40
3000	0.83	40	6.94	8.96	10.67	12.41	15.46	20.60
4000	1.11	40	7.04	9.08	10.87	12.61	15.76	21.09
410	0.11	50	6.49	8.03	9.02	11.62	11.99	13.73
486	0.14	50	6.80	8.50	9.63	12.31	12.98	15.12
684	0.19	50	7.35	9.35	10.77	13.40	14.87	17.91
803	0.22	50	7.58	9.69	11.17	13.79	15.66	19.10
1012	0.28	50	7.85	10.10	11.76	14.28	16.65	20.70
1404	0.39	50	8.19	10.59	12.46	14.87	17.84	22.69
1868	0.52	50	8.42	10.89	12.86	15.17	18.53	24.08
2000	0.56	50	8.47	10.99	12.96	15.27	18.73	24.38
3000	0.83	50	8.71	11.19	13.46	15.56	19.42	25.77
4000	1.11	50	8.84	11.39	13.66	15.76	19.72	26.47
410	0.11	60	7.86	9.72	10.97	14.09	14.37	16.42
486	0.14	60	8.23	10.30	11.66	14.87	15.56	18.11
684	0.19	60	8.89	11.29	12.96	16.15	17.84	21.49
803	0.22	60	9.16	11.68	13.56	16.65	18.83	22.98
1012	0.28	60	9.48	12.18	14.26	17.24	20.02	24.97
1404	0.39	60	9.88	12.77	14.96	17.93	21.41	27.26
1868	0.52	60	10.13	13.07	15.55	18.32	22.30	28.95
2000	0.56	60	10.23	13.17	15.65	18.32	22.40	29.25
3000	0.83	60	10.53	13.56	16.15	18.72	23.29	30.94
4000	1.11	60	10.63	13.66	16.35	18.91	23.68	31.74
486	0.14	70	9.75	12.18	13.76	17.63	18.43	21.39
684	0.19	70	10.53	13.46	15.35	19.31	21.21	25.47
803	0.22	70	10.92	13.96	16.05	19.90	22.40	27.26
1012	0.28	70	11.32	14.55	16.95	20.59	23.88	29.65
1404	0.39	70	11.82	15.25	17.95	21.37	25.57	32.54
1868	0.52	70	12.11	15.74	18.64	21.97	26.76	34.63
2000	0.56	70	12.21	15.84	18.74	22.06	26.96	35.02
3000	0.83	70	12.51	16.24	19.34	22.56	27.95	37.11
4000	1.11	70	12.71	16.43	19.74	22.75	28.54	38.11

Heating capacities, four-pipe coil (at high fan speed)

Water flow rate		Available temp. difference K	42GW 004	42GW 008	42GW 010	42GW 020
l/h	l/s					
68	0.02	20	0.39	-	-	-
80	0.02	20	0.41	-	-	-
150	0.04	20	0.50	1.01	1.10	2.58
200	0.06	20	0.53	1.10	1.21	3.07
250	0.07	20	0.55	1.17	1.29	3.44
300	0.08	20	0.57	1.21	1.35	3.73
400	0.11	20	0.59	1.28	1.43	4.18
600	0.17	20	0.62	1.35	1.52	4.75
800	0.22	20	0.63	1.39	1.58	5.09
1000	0.28	20	0.64	1.41	1.61	5.31
2000	0.56	20	0.66	1.47	1.68	5.82
3000	0.83	20	0.67	1.49	1.71	6.00
4000	1.11	20	0.67	1.50	1.73	6.10
<hr/>						
200	0.06	30	0.81	1.68	1.85	4.60
250	0.07	30	0.84	1.77	1.96	5.14
300	0.08	30	0.86	1.84	2.05	5.58
400	0.11	30	0.90	1.93	2.17	6.27
600	0.17	30	0.93	2.03	2.30	7.13
800	0.22	30	0.95	2.09	2.38	7.64
1000	0.28	30	0.96	2.13	2.43	7.97
2000	0.56	30	0.99	2.21	2.54	8.73
3000	0.83	30	1.00	2.24	2.58	9.01
4000	1.11	30	1.00	2.26	2.60	9.16
<hr/>						
250	0.07	40	1.13	2.38	2.64	6.84
300	0.08	40	1.16	2.47	2.75	7.42
400	0.11	40	1.20	2.59	2.91	8.35
600	0.17	40	1.25	2.73	3.09	9.50
800	0.22	40	1.27	2.80	3.19	10.2
1000	0.28	40	1.29	2.85	3.25	10.6
2000	0.56	40	1.32	2.96	3.39	11.6
3000	0.83	40	1.33	2.99	3.44	12.0
4000	1.11	40	1.34	3.01	3.47	12.2
<hr/>						
300	0.08	50	1.46	3.11	3.47	9.27
400	0.11	50	1.51	3.26	3.66	10.4
600	0.17	50	1.57	3.43	3.88	11.9
800	0.22	50	1.60	3.52	4.00	12.7
1000	0.28	50	1.62	3.58	4.08	13.3
2000	0.56	50	1.66	3.70	4.25	14.6
3000	0.83	50	1.67	3.75	4.31	15.0
4000	1.11	50	1.68	3.77	4.34	15.3
<hr/>						
350	0.10	60	1.83	3.91	4.37	12.0
400	0.11	60	1.85	3.99	4.48	12.6
600	0.17	60	1.92	4.20	4.75	14.4
800	0.22	60	1.96	4.32	4.91	15.5
1000	0.28	60	1.98	4.39	5.00	16.2
2000	0.56	60	2.03	4.55	5.22	17.7
3000	0.83	60	2.05	4.61	5.30	18.3
4000	1.11	60	2.06	4.64	5.34	18.6
<hr/>						
400	0.11	70	2.17	4.68	5.26	14.7
600	0.17	70	2.25	4.92	5.57	16.8
800	0.22	70	2.29	5.05	5.74	18.1
1000	0.28	70	2.32	5.14	5.86	18.9
2000	0.56	70	2.38	5.32	6.10	20.7
3000	0.83	70	2.40	5.38	6.19	21.4
4000	1.11	70	2.41	5.42	6.24	21.7

Available temperature difference = hot water entering temperature – entering air dry bulb temperature
 Maximum operating water temperature 80°C, maximum operating pressure 14 bar

Air throw, m

42GW	Louvres all open			One louvre closed			Two louvres closed		
	High speed	Medium speed	Low speed	High speed	Medium speed	Low speed	High speed	Medium speed	Low speed
004	3.8	3.2	2.7	4.3	3.7	3.0	4.8	4.1	3.4
008	4.0	3.4	2.8	4.5	3.8	3.2	5.0	4.3	3.5
010	4.8	4.1	3.4	5.3	4.5	3.7	5.8	4.9	4.1
012	3.0	2.6	2.1	3.5	3.0	2.5	4.0	3.4	2.8
016	3.4	2.9	2.4	3.9	3.3	2.7	4.4	3.7	3.1
020	4.3	3.7	3.0	4.8	4.1	3.4	5.3	4.5	3.7

Notes:

1. The louvres were adjusted to use the Coanda effect to obtain an air flow pattern that adheres as closely as possible and parallel to the ceiling.
2. The air throw is defined as the distance at which air flow speed falls to 0.2 m/s, when the air flow leaves the unit parallel to the ceiling.
3. The values are to be considered as indicative, as they may vary according to the type of ceiling, room dimensions and even the furniture used.

Coil water content

42GW	004	008	010	012	016	020
Water content	0.55	1.1	1.1	1.6	2.4	2.4

Operating limits

Water circuit	
Maximum water-side pressure	1400 kPa
Minimum entering water temperature	+4°C
Maximum entering water temperature	+80°C
Room air	
Minimum temperature	5°C*
Maximum temperature	32°C
Power supply	
Nominal single-phase voltage	230 V, 50 Hz
Operating voltage limits	198 V-264 V

* If the room temperature can go down to 0°C, it is advisable to empty the water circuit to avoid damage caused by ice.

Sound levels

42GW	Lw(A)			Lp(A)			NR		
	High speed	Medium speed	Low speed	High speed	Medium speed	Low speed	High speed	Medium speed	Low speed
004	47	37	30	38	28	21	34	24	17
008	49	41	30	40	32	21	37	28	18
010	54	48	43	45	39	34	40	35	30
012	49	40	34	40	31	25	36	27	20
016	56	49	38	47	40	29	43	36	25
020	63	55	42	54	46	33	50	42	29

Sound pressure levels in dB(A) and noise ratings NR are for a ceiling-installed unit and measured in a room with a volume of 100 m³ and 0.5 seconds reverberation time.

Lp(A) - Sound pressure level, dB(A)
 Lw(A) - Sound power level, dB(A)
 NR - Noise rating, dB(A)

Pressure drops

Valve assembly kit

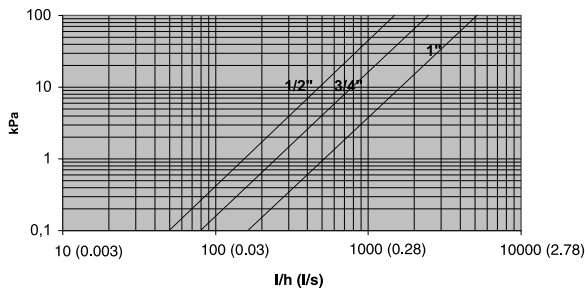

2-pipe coil

Coil only (water connections and valves not included)

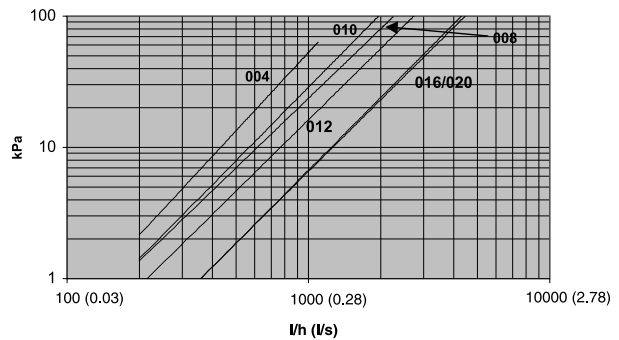

4-pipe coil

Coil only (water connections and valves not included)

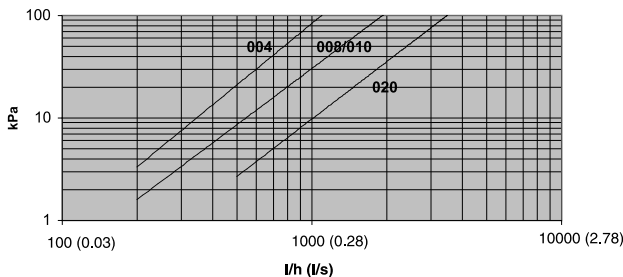

Order No. 14202-20, 02. 2001. Supersedes order No.: New.
 Manufacturer reserves the right to change any product specifications without notice.
 The cover photo is solely for illustration purposes, and is not contractually binding.

Manufactured by Carrier, Villasanta, Italy.
 Printed on Totally Chlorine Free Paper.
 Printed in the Netherlands.